

CUSTOMER OUTLINE DRAWING

REVISIONS			
REV	DESCRIPTION	DATE	APPR
1	Initial Release	05-May-17	S.X
2	DESIGN CHANGE	10-May-17	S.X
3	DESIGN CHANGE	06-Jul-17	S.X
4	DESIGN CHANGE	07-Jul-17	S.X

NOTES:

1.Material

- 1-1 Plunger: Copper Alloy,
- 1-2 Body: Copper Alloy.
- 1-4 Spring: stainless steel

2.Finish

- 2-1 Plunger:20u" Min. Gold over 50u" Min. Nickel
- 2-3 Barrel:10u" Min. Gold over 50u" Min. Nickel

3.Mechanical Specification

- 3-1 Spring Force:120gf MIN. at 2.03mm(0.08) Stroke
- 3-2 Durability:100,000 cycles

4.Electrical Specifications

- 4-1 Rating Voltage:36V max.
- 4-2 Rating Current: 4A max.
- 4-3 Contact Resistance: 30 mohms max.at working height

5.Environmental Performance

- 5-1 Storage and operating temperature range:
-40°C~+85°C
- 5-2 Humidity: 10% RH to 90% RH.
- 5-3 Salt Spray: 48H min.

6.Package: PE bag

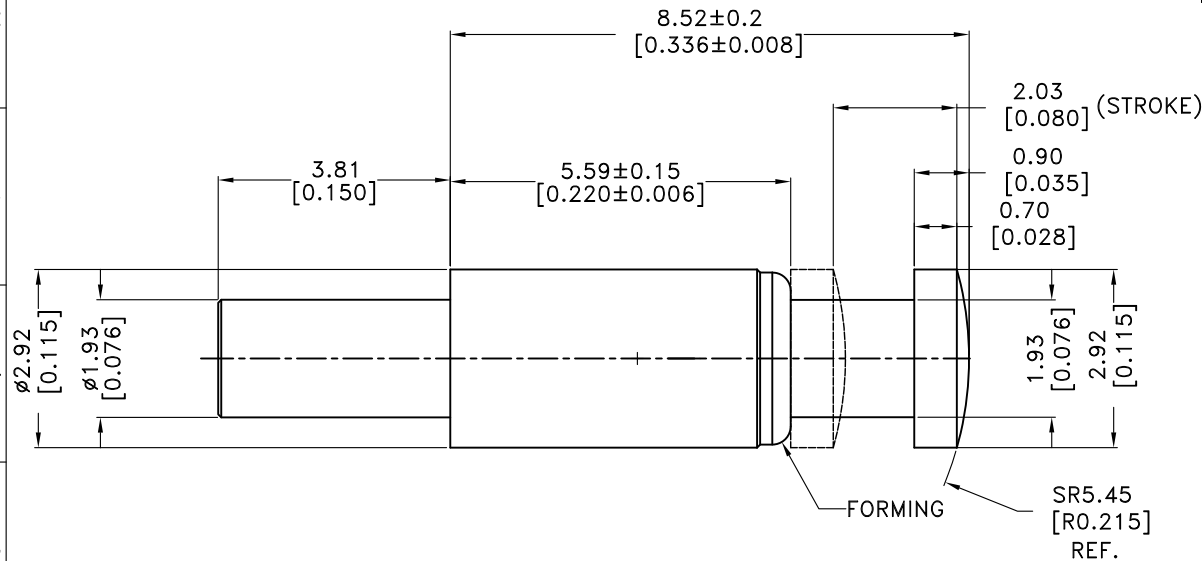

UNLESS OTHERWISE SPECIFIED,TOLERANCE ARE:
X.±0.5 .X±0.1 .XX±0.05 .XXX±0.005 ANGEL±2

NOTICE- These drawing,specifications,or other date are,and remain property of wizconn corparation.(2)are confidential and not to be disclosed to any person other than those to whom they are given by wizconn corparation,or to any other person to anyone for any purpose is not to be regarded by implication or otherwise in any manner liscensing, granting rights to permitting such holder or any others person to manufacture,use or sell any product,process or design, patented or otherwise,that may in any way be related to or disclosed by said drawings,specifications,or other date.

TITLE:

POGO PIN
($\varnothing 2.92 \times 11.43$)



深圳市为致康科技有限公司

Shenzhen Wizconn Technology Ltd.

USE ON: CUSTOMER	DESIGN: B.Zhang	DWG NO.: G081001-1		
MATERIAL:	CHECK: Scott.X	PART NO.: G081001-1		
FINISH:	APPROVED: Cliff.H	SCALE: 1:1	REV: 4	SHEET: 1 OF 1
THIRD ANGLE PROJECTION		UNIT: mm CAD FILE:		