

# CUSTOMER OUTLINE DRAWING

REVISIONS			
REV	DESCRIPTION	DATE	APPR
1	Initial Release	30-Jan-24	S.X

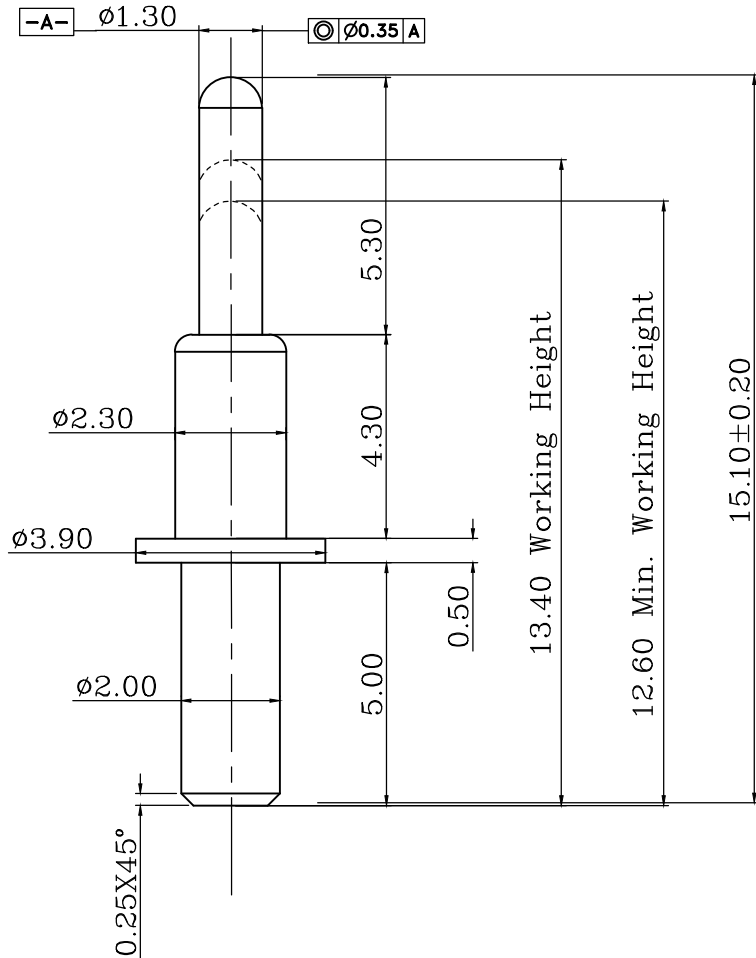

## NOTES:

- Material
  - Plunger: Copper Alloy
  - Body: Copper Alloy
  - Spring: Stainless Steel
- Finish
  - Plunger: 5u" Min. Gold over 50-100u" Min. Nickel
  - Body: 3u" Min. Gold over 50-100u" Min. Nickel
- Mechanical Specification
  - Spring Force: 40±10gf at 13.40 Working height
  - Durability: 10,000 cycles Min.
- Electrical Specifications
  - Rating Voltage: 24V
  - Rating Current: 2A
  - Contact Resistance: 30 mohms max. at working height
- Environmental Performance
  - Storage and operating temperature range: -55°C~+125°C
  - Humidity: 10% RH to 90% RH.
  - Salt Spray: 48H min.
  - Withstanding High Temperature: 260°C/10Sec
  - RoHS Compliant
- Package: PE bag

UNLESS OTHERWISE SPECIFIED, TOLERANCE ARE:  
 X.±0.5 .X±0.1 .XX±0.05 .XXX±0.005 ANGEL±2

NOTICE- These drawing, specifications, or other data are, and remain property of wizconn corporation, (2) are confidential and not to be disclosed to any person other than those to whom they are given by wizconn corporation, or to any other person to anyone for any purpose is not to be regarded by implication or otherwise in any manner licensing, granting rights to permitting such holder or any others person to manufacture, use or sell any product, process or design, patented or otherwise, that may in any way be related to or disclosed by said drawings, specifications, or other date.

TITLE: POGO PIN  
 (ø2.29\*15.00)

 深圳市为致康科技有限公司  
 Shenzhen Wizconn Technology Ltd.

USE ON: CUSTOMER	DESIGN: B.Zhang	DWG NO.: DP231513-1A-PB
MATERIAL:	CHECK: Scott.X	PART NO.: DP231513-1A-PB
FINISH:	APPROVED: Cliff.H	SCALE: 1:1 REV: 1 SHEET: 1 OF 1
THIRD ANGLE PROJECTION 	UNIT: mm	CAD FILE: